

Vent-A-Hood[®]
Air Recovery System
Owner and Maintenance Guide

Thank You For Choosing Vent-A-Hood[®]

We know you will be pleased with your purchase decision. Since 1933, our company has earned an outstanding reputation because of our commitment to performance, quality, and reliability.

The Importance of Cooking Ventilation

The main purpose of cooking ventilation is to capture the by-products of cooking. These by-products are heat, steam, smoke, odor, hazardous gases, and grease. Without proper cooking ventilation, these by-products can cause a great deal of harm to the home.

Safety

READ AND SAVE THESE INSTRUCTIONS

WARNING - TO REDUCE THE RISK OF FIRE, ELECTRIC SHOCK, OR INJURY TO PERSONS, OBSERVE THE FOLLOWING:

- A. Use this unit only in the manner intended by the manufacturer. If you have questions, call the manufacturer.
- B. Before servicing or cleaning unit, switch power off at service panel and lock the service disconnecting means to prevent power from being switched on accidentally. When the service disconnecting means cannot be locked, securely fasten a prominent warning device, such as a tag, to the service panel.
- C. Installation work and electrical wiring must be done by qualified person(s) in accordance with all applicable codes and standards, including fire-related construction.
- D. Sufficient air is needed for proper combustion and exhausting of gases through the flue (chimney) of fuel burning equipment to prevent back drafting. Follow the heating equipment manufacturer's guideline and safety standards such as those published by the National Fire Protection Association (NFPA), and the American Society for Heating, Refrigeration, and Air Conditioning Engineers (ASHRAE) and the local code authorities.
- E. When cutting or drilling into wall or ceiling, do not damage electrical wiring and other hidden utilities.

Safety (Continued)

WARNING - TO REDUCE THE RISK OF A RANGE TOP GREASE FIRE:

- A. Never leave surface units unattended at high settings. Boilovers cause smoking and greasy spillovers that may ignite. Heat oils slowly on low or medium settings.
- B. Always turn hood ON when cooking at high heat or when flambeing food (i.e. Crepes Suzette, Cherries Jubilee, Peppercorn Beef Flambe).
- C. Clean ventilating fans frequently. Grease should not be allowed to accumulate on fan or in blower housing.
- D. Use proper pan size. Always use cookware appropriate for the size of the surface heating element.

WARNING - TO REDUCE THE RISK OF INJURY TO PERSONS, IN THE EVENT OF A RANGE TOP GREASE FIRE, OBSERVE THE FOLLOWING:

- A. SMOTHER FLAMES with a close-fitting lid, cookie sheet, or metal tray, then turn off the burner. BE CAREFUL TO PREVENT BURNS. If the flames do not go out immediately, EVACUATE AND CALL THE FIRE DEPARTMENT.
- B. NEVER PICK UP A FLAMING PAN - You may be burned.
- C. DO NOT USE WATER, including wet dish cloths or towels - a violent steam explosion will result.
- D. Use an extinguisher ONLY IF:
 - 1) You know you have a Class ABC fire extinguisher and you already know how to operate it.
 - 2) The fire is small and contained in the area where it started.
 - 3) The fire department is being called.
 - 4) You can fight the fire with your back to an exit.

Safety (Continued)

CAUTION

TO REDUCE THE RISK OF FIRE, AND TO PROPERLY EXHAUST AIR, BE SURE TO DUCT EXHAUST AIR OUTSIDE. DO NOT VENT EXHAUST AIR INTO SPACES WITHIN WALLS OR CEILINGS, OR INTO ATTICS, CRAWL SPACES, OR GARAGES.

WARNING

TO REDUCE THE RISK OF FIRE OR ELECTRICAL SHOCK, DO NOT USE THIS FAN WITH ANY SOLID-STATE SPEED CONTROL DEVICE.

CAUTION

FOR GENERAL VENTILATION USE ONLY. DO NOT USE TO EXHAUST HAZARDOUS OR EXPLOSIVE MATERIALS AND VAPORS.

WARNING

TO REDUCE THE RISK OF FIRE, USE ONLY METAL DUCTWORK.

<p>THIS MANUAL SHOULD REMAIN WITH THE HOOD FOR FUTURE REFERENCE</p>

Operating Instructions

A. Models with Halogen Lights

Black Switch - This switch operates a single-speed motor. The single-speed motor is either off or on, and is not controlled by the SensaSource® heat sensor or the red switch.

Black Switch

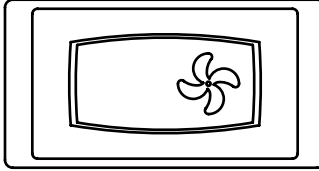

White Switch - This switch controls the lights. “LOW” level lighting (position I) is 25 watts per bulb, “HIGH” level lighting (position II) is 50 watts per bulb. Off is in the middle position.

White Switch

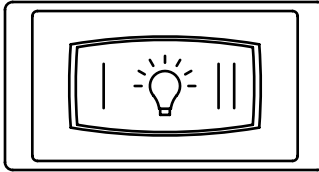

Hood Cleaning

A. Hood Canopy

Wipe down the interior and exterior of the hood as needed with a soft cloth and warm soapy water (liquid dish detergent is acceptable). Do not use acids, abrasives, strong detergents, solvents, or scouring pads. Stainless steel should be treated with a quality stainless steel cleaner such as Stainless Steel Magic® (Vent-A-Hood® part number SS64). Follow all label instructions. Do not polish across the grain or in circles.

B. Blower Unit

WARNING: To reduce the risk of personal injury, be sure the power is turned off in the hood before removing the shield(s) and blower housing(s).

The blower captures grease by-products in the grease pan attached to the bottom of the blower. Cooking habits determine how often the grease pan will need to be cleaned.

To remove the grease pan, unsnap the suitcase latches (A) (one on each side of the pan).

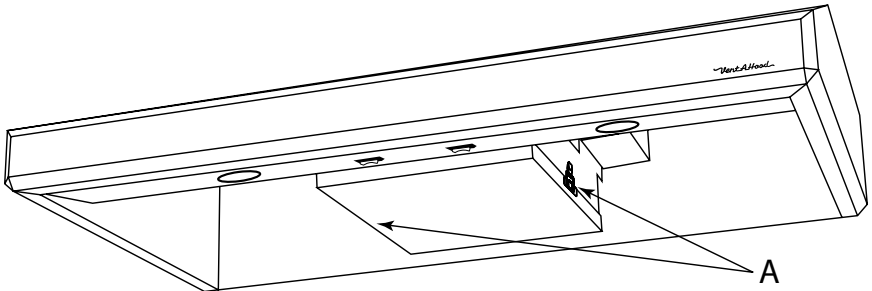

Hood Cleaning (Continued)

The grease pan (B) may now be lowered from the hood.

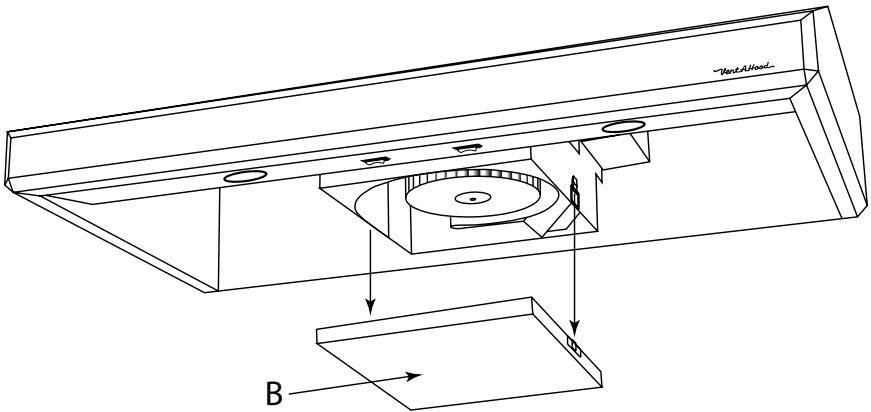

Clean the grease pan in a sink of warm, soapy water (liquid dish detergent) and let soak for a few minutes. Wash with a sponge or dishcloth, rinse and let drain. Reinstall the grease pan and snap the suitcase latches in place. The grease pan alternatively may be placed into a dishwasher.

C. Blower Wheel

WARNING: To reduce the risk of personal injury, be sure the power is turned off in the hood before removing the grease pan.

Regular cleaning of the grease pan should prevent grease accumulation on the blower wheel. If grease build-up should occur, the blower wheel may easily be cleaned in place using a soft bristle toothbrush and a common degreaser such as Formula 409®. Take care not to move or lose the metal balancing clips that may be affixed to the wheel.

In instances where the blower wheel may need to be removed, follow the instructions on the next page.

Hood Cleaning (Continued)

Remove the grease pan as described in Hood Cleaning, Section B. If the blower wheel needs to be removed, a $\frac{1}{8}$ " T-handle hex wrench is necessary. A T-handle hex wrench (A) may be obtained from Vent-A-Hood® to accomplish this (Vent-A-Hood® part number AW101). There is a small set screw on the side of the hub of the wheel that tightens up against a “flat” spot on the motor shaft. The set screw must be turned $\frac{1}{2}$ turn counterclockwise to remove the blower wheel. Insert the T-handle allen wrench through the guide hole (B) located next to the blower housing latch, through the blades of the blower wheel, and into the set screw. Use caution to avoid bending or distorting the blower wheel and take care not to move or lose the metal balancing clips that may be affixed to the wheel. If the wheel is difficult to remove, the area where the motor shaft makes contact with the blower wheel hub may need to be sprayed with a common penetrating oil such as WD-40®.

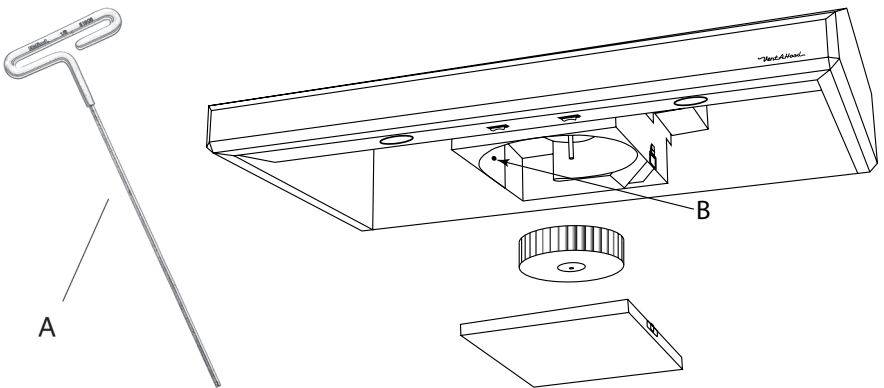

A soft bristle toothbrush with warm soapy water may be used to clean the blades, or soak the blower wheel in warm soapy water. When reinstalling the wheel onto the motor shaft, make sure the set screw makes direct contact with the “flat spot” on the motor shaft. Slide the blower wheel onto the motor shaft as far as it will go and tighten the set screw (clockwise) to lock the blower wheel in the correct position.

Maintenance/Troubleshooting

Replacing the ARS Filter Components

1. Remove the duct cover front panel. The panel is held in place with four snaps at the corners and at least one snap on the left and right. Begin by pulling the panel away at one corner either with finger tips or a plastic utensil. Work around the duct cover disengaging one snap at a time until all of the snaps are loose. Beware of sharp corners and edges. Use caution to prevent bending, scratching, or snapping the cover.
2. Lift the smoke trapping filter upward and remove it forward out of the duct cover. Discard filter with household refuse.
3. Lift the odor absorbing canister by the handles. Raise the canister so that the canister bottom is just above the bottom of the duct cover opening and slide the canister out of the duct cover. Replace activated carbon media or discard filter with household refuse.
4. Install new filters following the installation procedures in the ARS installation manual.

Replacing the Activated Carbon Media

1. Remove the odor absorbing canister by following the procedure above.
2. Remove the screws holding the cover inside the top of the odor absorbing canister.
3. Invert the odor absorbing canister over a household refuse container. Shake the odor absorbing canister to remove all of the activated carbon pellets.
4. With the odor absorbing canister upright, refill the unit with the new activated carbon pellets (Vent-A-Hood part number PARS-C). Lightly shake or vibrate the odor absorbing canister to settle the pellets. Fill all voids completely and leave a small mound of pellets above the cover opening to allow for future settling.
5. Replace the cover using the screws that were removed in step 2 above.

Maintenance/Troubleshooting (Continued)

A. Light Bulb Replacement

WARNING: To reduce the risk of personal injury, turn off power and allow lights to cool before proceeding.

To remove the bulb, turn it counterclockwise. If the light is difficult to remove, it may be necessary to use the light bulb suction cup that has been provided with this manual.

Replace the bulb with a GU10 120 volt, 50 watt halogen bulb (Vent-A-Hood® part number P1110).

B What To Do If...

Smoke is in the kitchen. Check the following:

Is the hood sized appropriately for the type of cooking equipment it is ventilating?

The purpose of a hood is to collect cooking contaminants and hold them until the blower unit can exhaust them to the outside. Therefore, it is necessary to size the hood based on the type of cooking equipment that is being used. Whenever possible, hoods should overlap the cooking equipment by at least three inches on each side. The hood should also project out to the front edge of the front burners. Finally, the height of the hood can affect its performance. Generally speaking, taller hoods are more suitable for professional style ranges, whereas under cabinet hoods are recommended for standard cooking equipment.

Does the blower capacity of the hood match the cooking equipment it is over?

K250 Single Blower - For standard electric or small gas cooking equipment.

Is the hood mounted at the appropriate height off of the cooking surface?

The height of the hood off the cooking surface is very important. The higher the hood is mounted, the less effective it will be. Hoods only collect cooking vapors; they will not pull cooking contaminants back into the hood if they escape unto the kitchen. Generally speaking, the deeper the hood, the higher the hood can hang and still be effective.

K Series Wall Mount

24"

Maintenance/Troubleshooting (Continued)

Is the hood making a rubbing or scraping noise?

This may be caused by the blower wheel coming in contact with the blower housing. Refer to Hood Cleaning, Section C for blower wheel installation details.

NOTE: If smoke still enters the kitchen after following these suggestions, contact your dealer for additional service and/or suggestions.

Warranty

Vent-A-Hood® warrants to the original consumer-purchaser its products to be free of defects in material and workmanship for a period of one year from the date of purchase with the following limitations:

- A. Light bulbs
- B. Freight damage
- C. Damage caused by faulty installation
- D. Incidental or consequential damage
- E. Commercial application
- F. Misapplication or modification of or to any part of the Vent-A-Hood® product

Service

To make a warranty claim, contact the dealer where the hood was purchased. They will contact the appropriate service agents. It is not necessary to register the product directly with Vent-A-Hood®.

VentAhood®

Vent-A-Hood Ltd.
P.O. Box 830426
Richardson, TX 75083-0426
(972) 235-5201
www.VentAHood.com
Customer_Service@VentAHood.com